

Spatial Orientation and the Notion of Constant Oppositions

Dixie Durr and Brenda Farnell

Whether we like it or not, those of us who deal with so called, 'non-verbal' materials are faced at the outset with major problems of translation, transcription, and transliteration; that of a space/time system, whether is it a dance, a rite, a ceremony, a system of greetings or what you will, into spoken and more accurately, into *written* language. We are all well aware that space/time systems occupy geographical spaces which are at once 1. physical, 2. social, 3. semantic, 4. conceptual. We must use written language to communicate to others *about* the system as we use spoken language to *express* the system, but we also know that spoken or written language introduces other things into the system. As Ardener has pointed out, conventional language intrudes itself into the system (1975), and it is simply a nonsense to imagine that it does not.



Drid Williams (1976)

As human beings we constantly orientate ourselves in at least three dimensions of space and one of time. Without any specific concentration, throughout all daily activities, we consistently do this without any difficulty. The problem that arises upon consideration of the above quotation refers to the need for investigators in the field of human movement to have systems of reference with regard to spatial orientation that are constant. We believe that fundamental human spatial orientations are most clearly discussed using the terminology of Labanotation informed by theoretical propositions set forth in semasiology. We propose to discuss the constant properties of spatial orientation in these terminological and theoretical contexts in this paper.

A Standard System of Referents

Because of the pull of gravity, 'up' and 'down' tend to remain fairly constant in our thinking: our kinesthetic sense tells us where we are spatially in relation to gravity's pull regardless of what position our bodies are in. We normally tend to know where 'up' is (with reference to ceiling or sky) and where down is (with reference to the floor or the ground) even with our eyes closed — assuming that we are on the earth and that we have normal proprioceptive functions and ear canal fluid.

Users of Labanotation assume this point of view and call it a 'standard system of reference,' or 'cross of axes.' It is notated in a movement text as . The system is standard because 'up' goes against the pull of gravity and 'down' goes with the pull of gravity. A longitudinal axis is thus established that is perpendicular to a ground or floor plans and this axis corresponds to the line of gravity of the body.

Whatever position the body is in,  (i.e. 'place high') is towards the ceiling or sky, and  (i.e. 'place low') is towards the floor or center of the earth.

What are the consequences of this in movement? The reader is asked to visualize (or to actually 'act out') the following example: stand up, walk forward three paces, turn to the left, walk forward one pace, turn to the right,

take a step backwards and kneel down. The spatial pattern of these moves would remain the same with eyes open or closed. However, if the reader can visualize one or two other persons following exactly the same directions but starting from chairs placed so that they face different directions in the room, it will become clear that although the directions 'up' and 'down' remain constant for him or herself and anyone else performing this pattern of moves, all the other directions given (i.e. 'right' and 'left' and 'forward' and 'backward') are taken from each individual's own body front. Thus it is clear that even with reference to the simple set of movement directions given above, there are two interacting referents for spatial orientation: gravitational pull and the frontal surface or 'plane' of the agent's own body. Writers of movement in the Laban system assume the view that people in western cultures — even if they haven't thought about any of this at all — use this standard system of interacting referents for their spatial orientation. This, however, need not always be the case.





A Body Frame of Reference

The body of the actor *can* be chosen as the point of reference from which all spatial directions are understood, including 'up' and 'down.' For example: if someone were asked to lie down on the floor or sofa, and then told to stretch their legs 'down' and arms 'up,' it is probable that they will extend both arms and legs along the floor plane and that these body members will remain in contact with it. If so, the person is now using, not the standard frame of reference that we started with, but a body frame of reference that ignores the pull of gravity in its interpretation of the meaning of 'up' and 'down.' Here, (place high) is conceived of as 'above the (or my) head' and (place low) as 'beneath my feet,' regardless of body position. Here, the up/down dimension corresponds to the body's own longitudinal axis (i.e. the line of the spine).

When the body is used as a spatial reference point, other words begin to be involved through which we express location in space; specifically *ourselves* (i.e. our own bodies) in relation to space, as, for example, 'in front of,' 'behind,' 'above,' 'below,' 'to the side of,' 'to the right' and so on. The concepts implied by these terms are also related to objects in space. We consistently use objects external to our own bodies as reference points, locating them in relation either to ourselves or to other objects; 'the chair is *in front of* the table,' 'the rug is *beneath* the table,' and the like.

What is often overlooked, of course, is that all these expressions describe *relations*: one cannot just be 'in front of,' one must be in front of something or someone — or 'below' or 'above' something. These positional expressions are always relative to something else and because of this, it is important to remember that in descriptions of the spatial aspects of human movements or action systems, it is *relationships* that are being described.

'Fixed Point' Constants

A third possibility of dealing with spatial referents is that of using fixed points such as the walls of a room as the constants for description. One may also use a fixed point *in* space, as Williams used the high altar in her score of the post-Tridentine Mass (1975). Notators of movement in the Laban system refer to this frame of spatial of reference as a *constant system of reference*, or 'constant cross of axes' in which case  still refers to ceiling (away from gravity) and  refers to floor (against gravity), but  (forward) and  (backward) will have a fixed referent of walls or place in the particular space.

An example of this can be seen in Figure 1, where a teacher has asked a pupil to come to the front of the classroom, but to do so, the pupil has actually moved *backwards* to reach the prescribed, or agreed upon, 'front' of the room:

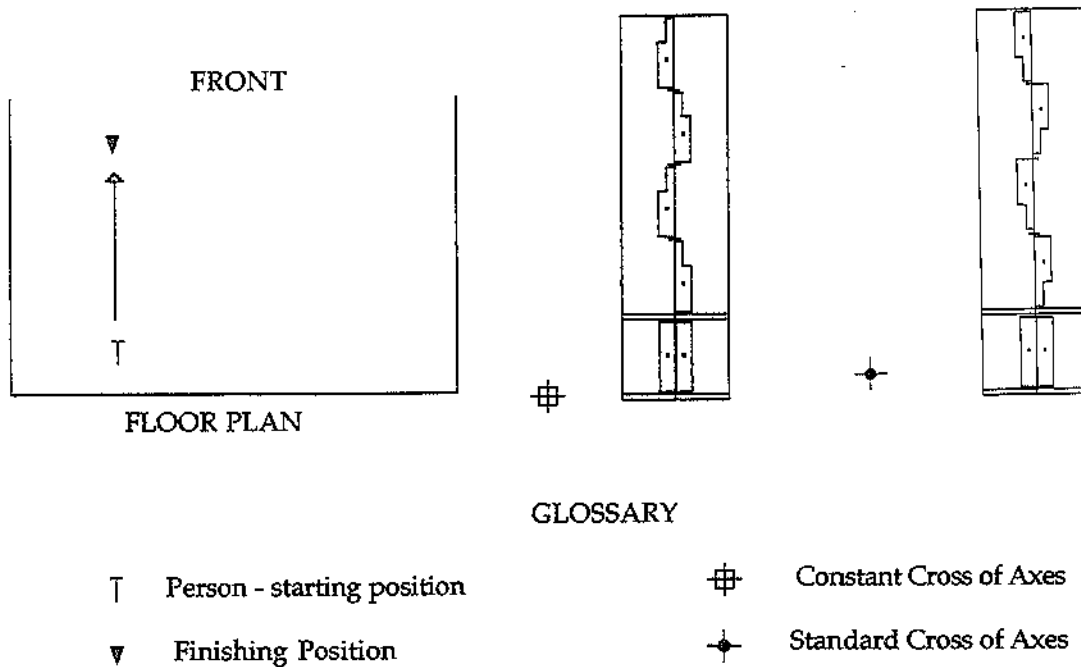

Figure 1

It is interesting that Labanotation has chosen as a 'standard' that which infers the most commonly used Western conventions of a combination of body referents and spatial referents. 'Up/down' or the vertical dimension in gravitational terms, is considered spatially constant, but 'front/back' and all other directions assume a body referent. That is to say that 'front' always relates to where the frontal plane of the torso of the agent is facing.¹

Laban notators, on the whole, assume that most western dancers think in these terms.² But it is this kind of assumption that, as anthropologists of human movement, we find it necessary to examine: each idiom of dancing — including the great variety of western forms — has an underlying conceptual frame of referents for its spatial orientation that is a distinctive feature of the particular idiom, as we will explain in a moment. We would want to ask, if particular idioms of western dance have characteristic features of spatial orientation, indicating that we cannot rightly assume a 'standard,' a 'body' or a 'fixed' system of reference for them, how dangerous are these assumptions when one is concerned with non-western forms of the dance and body languages?

The idiom of ballet uses two clearly different systems of spatial referents; a combination of 'body' and 'fixed point' reference. The first is evident in terms like '*en avant*' (to the front), '*devant*' (in front of) and '*derriere*' (in back of), which clearly establish a body reference.³ Spatial directions for traveling through space are dealt with in this idiom by 'fixed' reference points of walls and audience; the corners and the walls of the practice room (or stage) are numbered.⁴ The ballet dancer has to use two frames of reference: a body cross of axes; \ominus , to concentrate on positions of the arms, legs and torso, and a spatially constant cross of axes; \oplus , to orientate that position (or movements) in relation to the stage/audience/room. Other examples could be given, but we wish to get on with the significance of these facts with regard to the criteria of identity that we use in our claims that dancers using different idioms of movement (but who appear to be using 'the same' movements to an observer) are *not* really doing 'the same things.'

Internal Codes

The reader is asked to examine the eight measure sequence of movements⁵ found in Appendix 1A. This sequence, as written, is based on the Standard Cross of Axes. These action signs would be *written* 'the same' had the notator chosen to use either the Body Cross of Axes or the Constant Cross of Axes, since the performer (hereafter referred to as 'X') is facing the same 'front.' However, should X establish a different front, for example, stage right, and conceptualize the movement phrase as if it were based on *the constant directions of the room*, the notation should appear as written in Appendix 1B. It is important that readers compare carefully the written elements of the texts, for, to those of us who take the concept of 'body language' seriously, written texts of movement yield at least as much 'deep structural' information as written texts of conventional language reveal to a linguist.

Our point is this: if this same sequence were danced by three performers, each dancing the sequence with *a different system of spatial referents* in mind, whilst lying on the floor, there would definitely be a problem with the spatial differential of up/down unless the reference system is clear established at the outset. Appendices 2A and 2B show the eight measure phrase as performed from the standpoint of each of the systems of reference. To an untutored observer, it might appear that all three performers were doing the 'same' movements, however, it is obvious from the notation that for one performer (X), count 1 of measure 3 is 'place high' (or towards the ceiling), whilst performer Y (in Appendix A) executes the same position as 'forward middle' of the body, even though the arms are moving towards the ceiling.

To view the three dancers in the light of an assumption that they are all 'speaking' (or 'dancing' or 'expressing') the *same* code that is internal both to them and to their idiom is quite wrong. It is therefore extremely important that empirical observation not be considered the only criterion by which one determines what the particular performance is about — or what it 'means,' because the texts (especially Appendices 2A and 2B) of the three performers, each of whom use a different system of spatial reference reveals important conceptual differences that underlie the manifest movements of each performer.

The 'ethnographic texts' in Appendices 2A and 2B of three performers, each of whom use a different spatial system of reference reveals the differences in the conceptual frameworks of each performer. Semasiology teaches that what we see notated there is the *transitive structures*⁶ of the actions. Following Ardener, if one then considers the 'p' and 's' structures at work, there are clearly three different 'codes' resulting in what would appear to an observer as 'one' similar movement phrase.⁷ When an impartial observer studies the texts of the movements, the different p-structures are made visible; when the performances of the three dancers are seen, these p-structures are *not* visible, yet, examination of the movements of each dancers reveals how "... an action sign unites a concept and an action" (Williams 1979: 47).

Looked at in this way (see Figure 2) Labanotation is merely the means by which these different conceptual frameworks are made literate — and therefore more easily comprehensible. Williams has pointed out that there is a fundamental duality involved with action signs or symbols, expressed first in the relation between mover and watcher, and second, in the internal relational between thought and action for the performer (Williams 1979: 42-43). That is to say that there is a relation between mental images (or concepts) and articulated motions.⁸ Thus, the motions of the three dancers, viewed by an observer who did not understand (or perhaps have a basic awareness) that three different systems of spatial referents were involved, would simply see 'bodies in space' more or less 'doing the same things.' Such an observer would "... apperceive the motions but remain outside the social facts" (Williams 1979: 43).

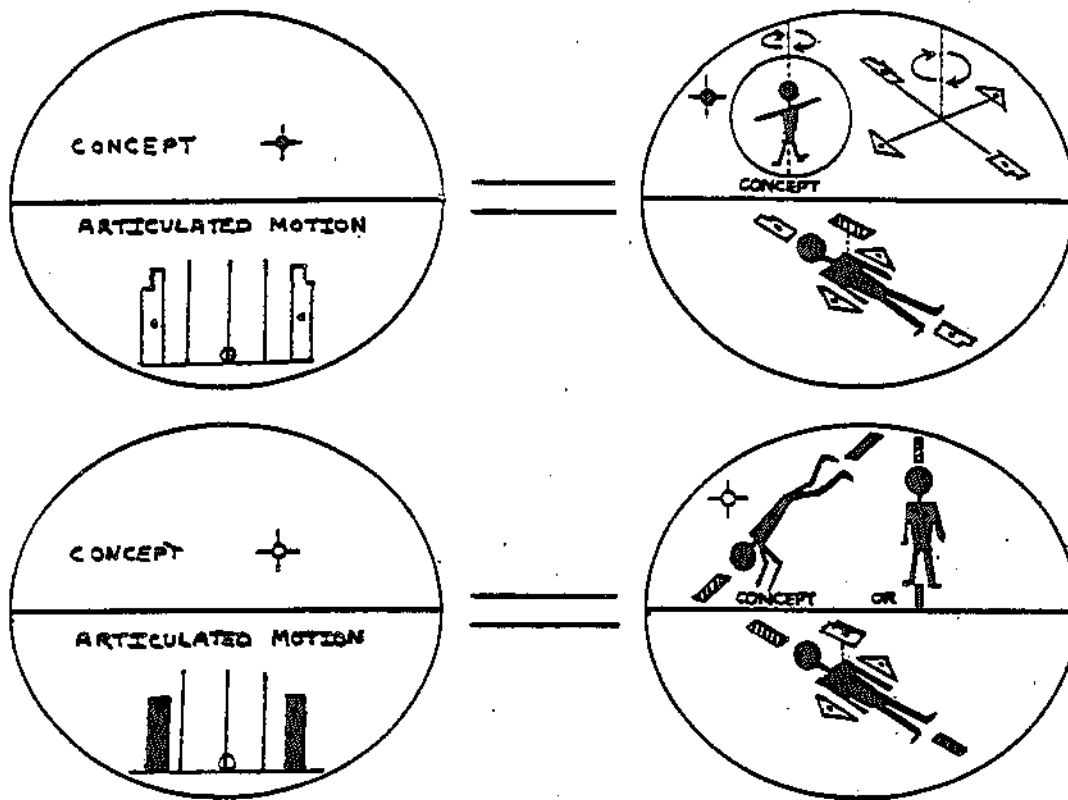

Figure 2

Constant Oppositions vs. Constant Frames of Reference

If it is possible to recognize differences of usages of spatial frames of reference among Western forms of dancing, can we not expect to find wider and greater variations of usage cross-culturally? Indeed, the three systems of referents and their combinations might not be enough because, for example, a system of spatial orientation might differ in a culture whose spoken language lacked the syntactical, adverbial and tense structures that characterize English speakers.⁹

What is constant however is the very notion of spatial oppositions, wherever the referents lie. The important point is that there must be such a notion in order for human beings to orient themselves in space at all, hence the semasiologist's theoretical concept of (capital) 'P' structures, i.e. the *intransitive* structures of up/down, right/left, front/back and inside/outside. Not only is the *notion* of opposition essential to the study of movement, the fact must be recognized that these structures are *interacting* dualisms. One must have a concept of 'down' for 'up' to make any sense at all; 'right' only exists as a concept in opposition to 'left' and so on.¹⁰

To widen the field of discussion for a moment beyond the dance, let us consider some other linguistic usages of oppositions in space: within western cultures, the usage of the terms 'up' and 'down' is certainly not constant. 'Up the street' and 'down the aisle' have nothing to do with ceilings and floors. New York City dwellers conflate the geographical concept of 'north' with *uptown* and 'south' with *downtown*. The British do not use this expression: the different spatial arrangements of cities in Britain (the result of different historical developments) generates talk of 'into' town or 'out' of town, with no geographical relations involved, even though 'north' is associated with 'up' and 'south' with 'down' when one speaks of traveling 'up to Liverpool,' or 'down to Brighton.' We do not often reflect on the fact that our usages of these 'dimensions' is not constant: if a map, for example, is laid horizontally on a table, then the 'up/down' or 'north/south' dimension refers to spatial points that are away from or towards the reader — they bear no relationship either to ceilings or floors or to geographical north and south. Our point here is that on a day-to-day basis, we constantly shift our spatial points of reference in these and other ways without (too much) confusion.

One would expect these kinds of variation to occur in other cultures, perhaps with even greater variation and possibly, with different *designata* with which to start. As anthropologists of human movement, we are obliged to note these variations along with the language used to describe spatial orientation and awareness in order that we might accurately analyze action sign systems. However they may be expressed or manifested, we expect the 'P' structures — the interacting dualisms — to be there.

It is *how* they are dealt with in dance idioms, sign languages, rites and the like, and *how* they are spoken about and used by members of the culture that will allow us to get closer to understanding the meanings of particular action signs, but we will not advance our understandings by inappropriately attaching ethnocentric notions of spatial meanings to the movement traditions of other cultures. To cite a familiar example; 'upward' gestures or movements = 'heaven,' 'hope' and 'aspiration,' but 'downwards' gestures or moves = 'hell,' 'earthiness' and 'despair.'

To summarize: a *standard* system of spatial referents is one in which the directions 'up' and 'down' are connected with the earth's gravitational pull on the body, that establishes an imaginary line perpendicular to the ground plane, where ▤ (place high) is always towards the sky and ▥ (place low) is always towards the center of the earth. A *body* system of referents is one in which the physical body of the actor is given the privileged position; that is, 'up' is, so to speak, always where the actor's head happens to be, so that in a head-stand, for example, 'up' and 'down' are conceived of as the reverse of those directions in the standard frame. A *fixed point* system of referents is one in which some feature (or features) of the external spatial environment — the walls of a room, say, or an object in the space other than the agent's body — is arbitrarily chosen as the 'constant set' for the specific dance, rite or what-have-you with which an investigator may be concerned.

These are, we believe, three fundamental concepts regarding orientation in space that are constituent to western societies, whether taken alone or in some combination. It would be scientifically irresponsible to say that we *know* in how far and in what ways these deictic features of orientation and spatial reference underpin the spatial orientations of *all* peoples in *all* societies, in *all* languages. They probably provide useful starting points for serious research. Our understanding of Haugen's analysis of Icelandic spatial orientation (1957) is informed by this kind of thing, but we also know that in the field of human movement studies, the nature and consequences of the systems we have so far discussed are usually taken for granted — or ignored.

The Semasiological Standpoint

Williams has taken a formalist's point of view: "It is important to realize that when dealing with the body-object and the bounded space in which it moves, we are dealing with a space which has fixed axes from an observer's point of view ... the dancer's orientation, by contrast, together with the space about to be described (belonging to the semasiological body itself) is based on moving axes" (1976: 163). Many of her statements, as the one just cited, concern the theoretical models we use that help to make sense of the complexities involved, even in the simplest of observable human actions. After all, one has to have *somewhere* to begin.

We have found the notion of 'intransitive' and 'transitive' structures very helpful: intransitive structures point to certain invariant aspects of movement. Transitive structures, on the other hand, connote features of movement and space that change. Intransitive structures define aspects of space and motion that are neither created nor produced by humankind — they just 'are,' so that the structure of interacting dualisms, like 'gravity' or 'rays of lights,' are accepted as 'givens.' We use the structure of interacting dualisms and the notions of the finite limitations of the human body as models that help us to make sense of the physical world around us, but we do not attribute their existence to humanity, although their expression as 'laws' is very human indeed.

An observer can, for example, watch a stone roll down the slope of a hill and because of the notion of a constant 'force'¹¹ called 'gravity' it is possible to investigate — and measure — the ways in which different-sized objects will behave; how differing degrees of slope-angle will affect the speed of the moving stone and the like. The laws of gravity are accepted, in our terminology, as 'intransitive structures.' They are a 'real' part of the 'real' world, but gravity itself is not something that was made by humans. Our point is this: the parameters of the theoretical concept of 'gravity' have to be accepted before analysis can even begin.

One does not start by asking, "Does gravity exist?" Similarly, we do not start by asking whether the spatial dimensions of up/down, right/left, front/back or inside/outside 'exist.' We accept these dimensions of space as givens. How these are dealt with and how they are conceived and made manifest in particular action sign systems by different ethnic and linguistic

groups are what we think of as the *transitive structures* of human actions. None of this presents problems to skilled notators of movement, nor is the concept of the 'semasiological body' a problem: it provides a means whereby semasiologists can accurately investigate and then talk about how particular movement systems *use* the body — not as a machine or in terms of its 'joint-functions,' but how it is used as an *expressive, communicative* instrument.¹²

The revolutionary leap that semasiology represents in the field of human movement studies is twofold: (i) for the first time, we possess the means whereby we can calculate the finite limits of possible human movements, and (ii) although the notion of the semasiological body is not in conflict with anatomists,' physiologists' and kinesiologists' concepts of movement limitations, it does not get bogged down in their concerns. The field of human movement studies in general has, we believe, labored under the misapprehension that in order to be 'scientific,' talk about the human body must necessarily involve the language and technical terminology of the worlds of bio-mechanics and kinesiology. We aim to be as 'scientific' as our colleagues in these related fields, but our main concern is with the semantics of action sign systems; the meanings of body languages, whether those are found in idioms of dancing or not.

Our question is not "Is there a human semasiological body?" but "How can we use this theoretical structure to make sense of empirical data?" As anthropologists of human movement, we are more concerned with the semantics of human anatomy. Thus, our descriptive apparatus has to differ from that of our colleagues (see pages 217-218 in the introductory article of JASHM Volume 1(4) for an example of what is meant).

Levels of Analysis

Some of the kinds of analysis we advocate in our discipline is, like that of kinesiology, semantically 'null,' but we do not imagine that a kinological¹³ level of explanation is the *meaningless*, 'scientific' explanation for levels of analysis that are semantically dense.¹⁴ We might begin our analysis, for example, by asking how the three degrees of freedom of the wrist are used in a given system. On a kinological level, we might begin by examining a movement script for the purpose of determining how the wrist moves through the duration of the whole dance (rite or whatever). How is the wrist related to other body parts and to the space in which it moves? What aspects of frequency and distribution of these moves is important? We are obliged to answer these questions through levels of 'one gesture' through a scale of longer and longer stretches, up to the level of 'a dance,' say, and if possible, beyond — to the level of its usage in an entire idiom.

As one moves up this scale¹⁵ one has to deal with the notion of 'semantic density' — and this is determined by the material one works with, for 'kinemes' are sometimes semantically loaded and sometimes they are not. Is the wrist a special 'signifier' of some kind and what is it that is 'signified?' Movement of the wrist in a dance, for instance, may or may not be of more *value*.¹⁶

Few would deny that the wrist is much more active in the hand gestures of Balinese or Indian classical dancing, in contrast to its usage in the *port de bras* of Western ballet, but even here, exceptions are to be found: in *Swan Lake*, the 'wash'¹⁷ of the swans' arms — in particular the wrist movements — is essential to the meaning of that particular ballet, but not to the idiom in general. A contrasting case of the importance of 'wrist' to 'meaning' might be that of its usage by the *Mimika* of New Guinea: Pouver's study (1973) informs us of their concept of *Ipu*, i.e. an 'essence of life' or 'vital force' that is located in the different joints of their bodies. If *Ipu* is located in a *Mimika*'s wrist(s), the movements necessarily assume added significance. Injury to, or immobilization of the wrists would render articulation in American Sign Language virtually possible, as it would so seriously impede a *Bharata Natyam* dancer that it would render him or her 'mute' in the body language. In any case, naive generalizations regarding 'gestures,' their 'universality' and such, are simply not good enough; they either tell us too little — or too much (see Puri, 1980: 189-194, for a critical review of work that tells us 'too little,' and Williams, 1974, for a critique of work that attempts 'too much').

Conclusion

We have only briefly touched upon some of the spatial and bodily considerations with which we are preoccupied here. Our researches turn around the question of what criteria can legitimately be used to say with confidence that stretches of movements in space are 'the same.' The question itself is not new: Goodman (1969) expresses the same concern when he asks Labanotators and movement specialists for 'criteria for identity of behavior.' We have not by any means offered a 'definitive answer,' but have attempted to direct our audience's attention to features of spatial environment and bodily movement that, by their *absence* in rival theoretical approaches, tend to place too many constraints on movement investigations and our potential to understand.

Semasiological theory, using Labanotation, offers a sophisticated means of dealing with bodily and spatial referent systems. Its complexity, however, merely matches the complexity of human movement in the first place: other theoretical approaches tend to reduce the complexity. The observations and insights in E.T. Hall's work, for example, whilst identifying many interesting and enlightening features regarding human spatial relationships, offer nothing but the concept of 'proximity' with which to deal with spatial relations. In addition, 'proxemics' is tied to the currently popular view that somehow, in order to be 'verifiable,' analyses of human movement have to be tied to ethological considerations of the 'critical distances' of the animal world.

In this paper, our major concern has been with three human concepts of spatial orientation that originate, we believe, in Western societies. We call these systems of referents (in agreement with Labanotation) 'crosses of axes':

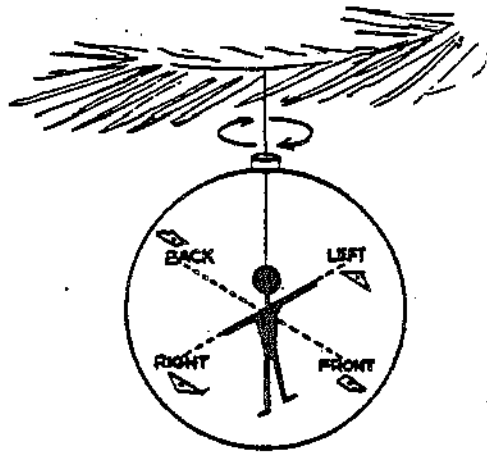

1. The standard cross-of-axes:
Where the up/down axis is a plumb line that always relates to the pull of gravity. This element remains 'constant.' Other directions change according to the front of the torso of the mover. We visualize this as if seeing the body contained in a Christmas tree ornament that dangles in space. The bauble hangs down constantly because of gravity, but may revolve clock-wise or anti-clockwise, its 'front' turning around with it.

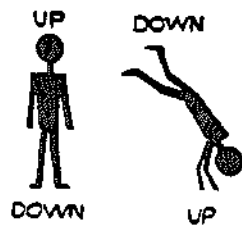

2. The body cross-of-axes:
Where the body's head and feet correspond to the directions of 'up' and 'down' and gravity is, as it were, ignored.

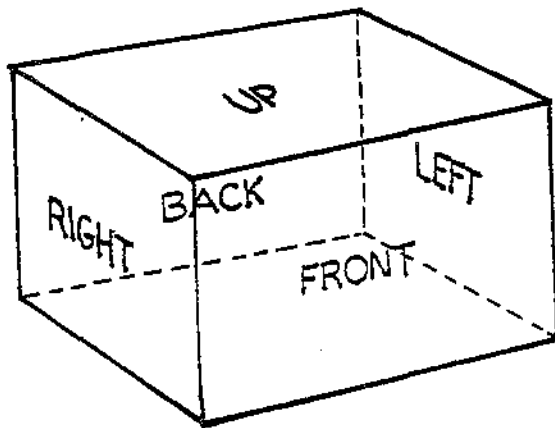

3. The constant cross-of-axes:
Where external points of reference, as the walls — or an object — in a space is made 'constant' such that moving 'to the side' (front, back, etc.) does not depend on body facings.

In semasiology, we often think of the Christmas tree ornament hanging in an imaginary cuboidal structure, thus we say that human beings really move all the time in six dimensions of space — and at least one of time. How many 'programmatically' concepts of space besides these might exist in human domains

we do not, at present, know. From our experience (see Durr 1981: 132-138) we are always prepared to encounter something different. We doubt, for instance, that a Navajo concept of movement and space could be translated 'carte blanche' into any of these terms (see Worth and Adair 1972). An Ardenerian concept of 'p-structures' applied to spatial referents may abound: what we protest against is the unexamined applications of our own ideas onto others. Semasiological theory has in-built protections against this kind of thing.

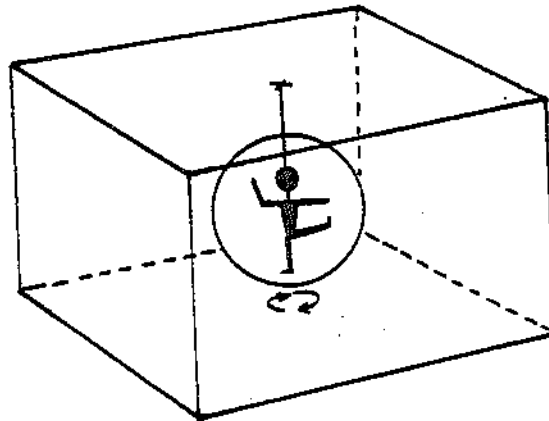

Endnotes

¹ Our use of the word 'plane' is synonymous with anatomical and medical usages and refers to a two dimensional surface. The frontal plane here referred to is vertical and divides the body into a front half and a back half.

² Labanotators, quick to proclaim the potential that exists for a global application of the system, often labor under naïve assumptions about the 'universality' of movement and assume that to record what is seen, i.e., gross physical movement, is sufficient. Anthropology teaches us that this will not do. Movement languages are no more universal than spoken languages, and observation is certainly not enough. See Durr (1981).

³ See Williams (1980) for a detailed discussion of 'Ballet French' and body referents in relation to spoken French.

⁴ Classical ballet adopts the following convention for the stage and practice space.

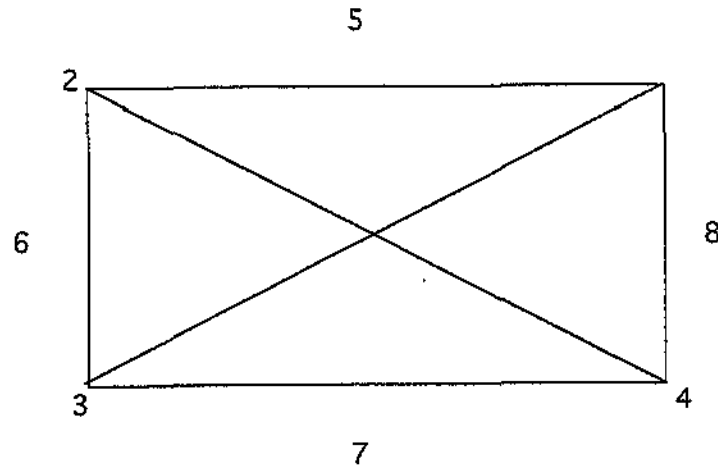

1,2,3,4 = Corners

5,6,7,8 = Walls

(From *A Manual of Classical Theatrical Dancing* (according to the method of Cav. Enrico Cecchetti), C. Beaumont (with I. Idzikowski) 1940, London.)

⁵ The eight measure notation sequence has been written as simply as possible to emphasize the theoretical points being discussed.

⁶ See Williams (1979) for explanation of transitive and intransitive structures.

⁷ In semasiological theory, p:s refers to a parts:whole relationship and p/s refers to code/message relationships (Williams 1979). For the original discussion of p and s structures, see Ardener (1973).

⁸ Saussure's principle of the relationship between sound image and concept in spoken language, is here applied to the relationship between action, i.e. articulated motion, and concept. The oval-shaped diagrams in the paper are based upon this Saussurian principle. We are aware too of other relations that exist between image and articulated motion, as for example in the work of Sweigard (1974).

⁹ Worth and Adair's work with the Navajo indicates that greater variation does exist, but the extent to which this is so is not yet known.

¹⁰ See Williams (1976 and 1979) for further discussion of interacting dualisms in semasiology, and Hertz's classic essay of 1909 regarding the notion of binary oppositions in *Right and Left*. R. Needham (Ed.) 1973.

¹¹ See Harré (1972: 64-69) for discussion of the concept of mechanical force in relation to Newtonian physics and epistemological problems surrounding what we consider to be 'hard' scientific knowledge.

¹² "The concept of the semasiological body draws attention to an important distinction which must be made between the *biological* identity of the dancer and the *social or symbolic* identities of the dancer, who, being human, is capable of consciously assuming multiple identities with reference to systems of symbolic actions." (Williams 1976: 124).

¹³ See Williams, 1975: 31-32.

¹⁴ Following Best (1981; lecture notes) we believe a distinction must be made between physical explanations of 'movement' and semantic concerns. In semasiology we consider even the kinological level of analysis to be in the semantic realm for it is part of a continuum ranging from semantically null to semantically dense, but *not* semantically *void*, as explanations in terms of muscles, bones, etc. would be devoid of 'meaning' in any social or communicative sense.

¹⁵ See Williams (1976: 129, 1979: 52) for all levels of this scale.

¹⁶ The meaning of the word 'value' here is after Saussure's use of the French word '*valeur*.' In general it has to do with features of 'weighting' or 'valency' and does not carry implications of moral or other kinds of evaluations.

¹⁷ The movement of the swans' arms is known as 'the wash.'

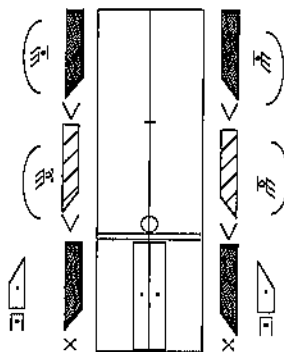

References Cited:

Ardener, Edwin W.

1973. Some Outstanding Problems in the Analysis of Events. Paper presented to ASA Decennial conference in Britain. In *Symbol and Sense*. (Eds. Foster and Brandes) Academic Press, New York 1980: 302-322. Also in *The Yearbook of Symbolic Anthropology* (Ed. E. Schwimmer). London: C. Hurst & Co.; McGill: Queens University Press (1978).

Best, David

1981. Lecture notes. New York University.

Durr, Dixie

1981. Labanotation: Language or Script? *JASHM* 1(3): 132-138.

Goodman, Nelson

1969. *Languages of Art*. Oxford: Oxford University Press.

Hall, Edward T.

1966. *The Hidden Dimension*. New York: Anchor Books.

Harré, R.

1972. *The Philosophies of Science*. Oxford University Press.

Haugen, Eingar

1969 [1957]. The Semantics of Icelandic Orientation. In *Cognitive Anthropology*. (Ed. S. Tyler), New York Holt, Rinehart & Winston.

Needham, R. (ed.)

1973. *Right and Left. Essays on Dual Symbolic Classification*. Chicago and London: University of Chicago Press.

Pouwer, Jan

1973. Signification and Fieldwork. *The Journal of Symbolic Anthropology* 1 (1) July.

Puri, Rajika

1981. Review of Morris, Collett, et al, in *JASHM* 1(3): 189-194.

Saussure, Ferdinand de

1966 [1949]. *Course in General Linguistics*. (Eds. Bally and Sechehaye; Trans. Baskin). New York McGraw-Hill (1966).

Sweigard, Lulu

1974. *Human Movement Potential: Its Ideokinetic Facilitation*. New York: Harper & Row.

Williams, Drid

1974. Review of A. Lomax, A. et al. *Choreometrics*, in *Dance Research Journal* Vol. I/2. New York: CORD.

1975. The Role of Movement in Selected Symbolic Systems. D. Phil. Thesis. Oxford University, England.

1976. Deep Structures of the Dance. *Journal of Human Movement Studies*. Part I in Vol. 2: 123-144); part II in *Yearbook of Symbolic Anthropology*, London: I.C. Hurst & Co.; McGill: Queens University Press (1978).

1976a. An Exercise in Applied Personal Anthropology. *Dance Research Journal*, Vol. IX/1 (Fall/Winter 1976-77). New York: CORD.

1979. The Human Action Sign and Semasiology. *Dance Research Journal Annual X*. CORD, New York.

1980. Taxonomies of the Body. *JASHM* Vol. 1(1): 1-19; Vol. 1(2): 98-122.

Worth, Sol and John Adair

1972. *Through Navajo Eyes*. Bloomington and London: Indiana University Press.

Appendix 1A

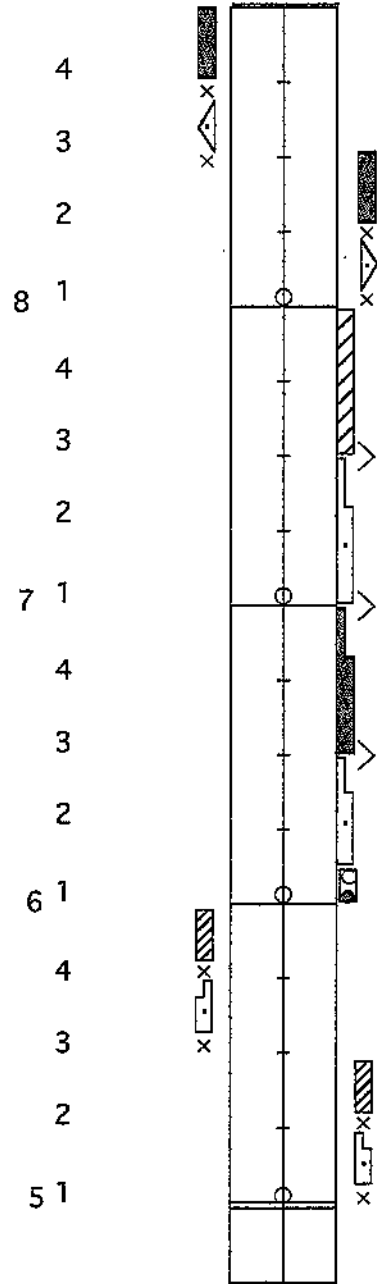
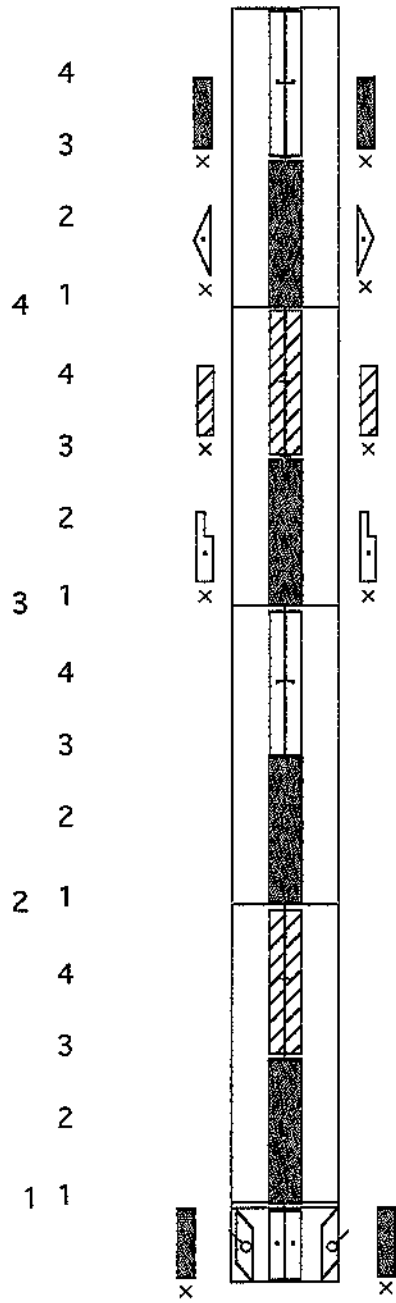

Appendix 1B

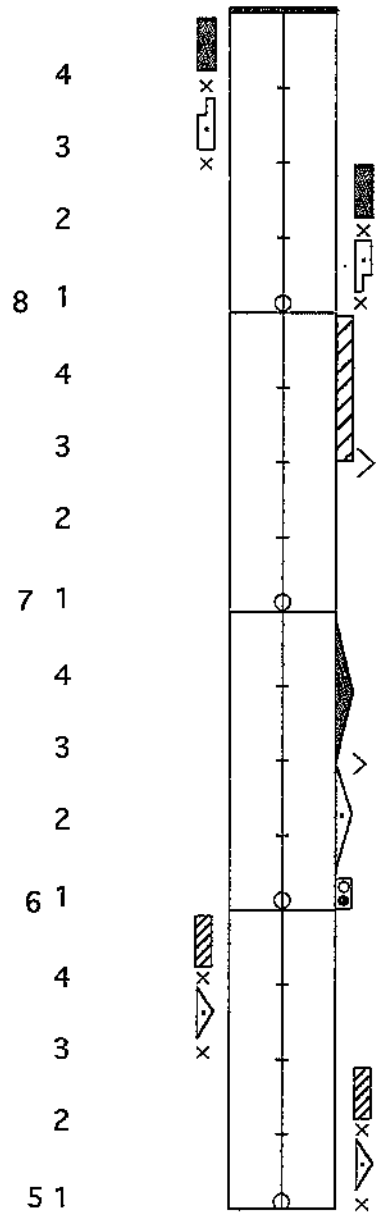
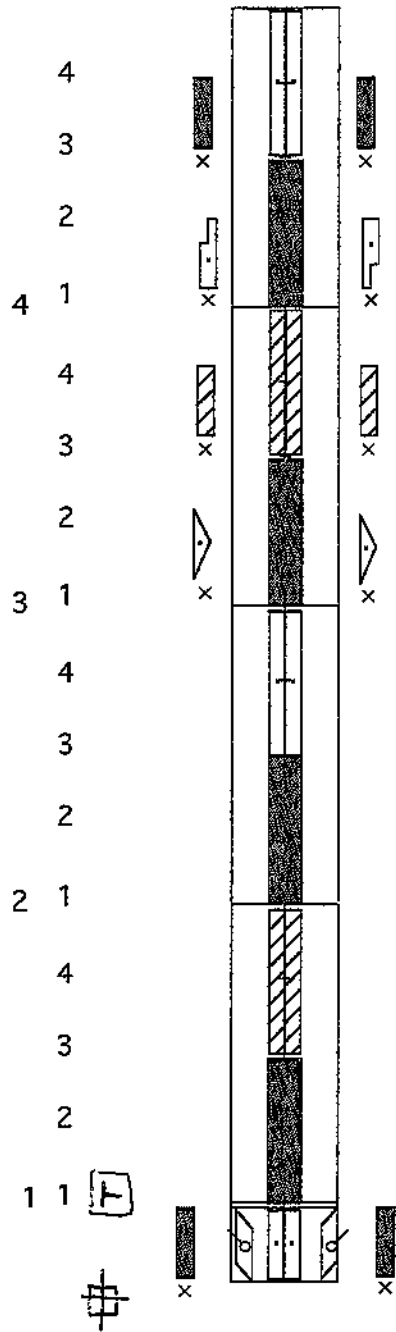

Appendix 2A

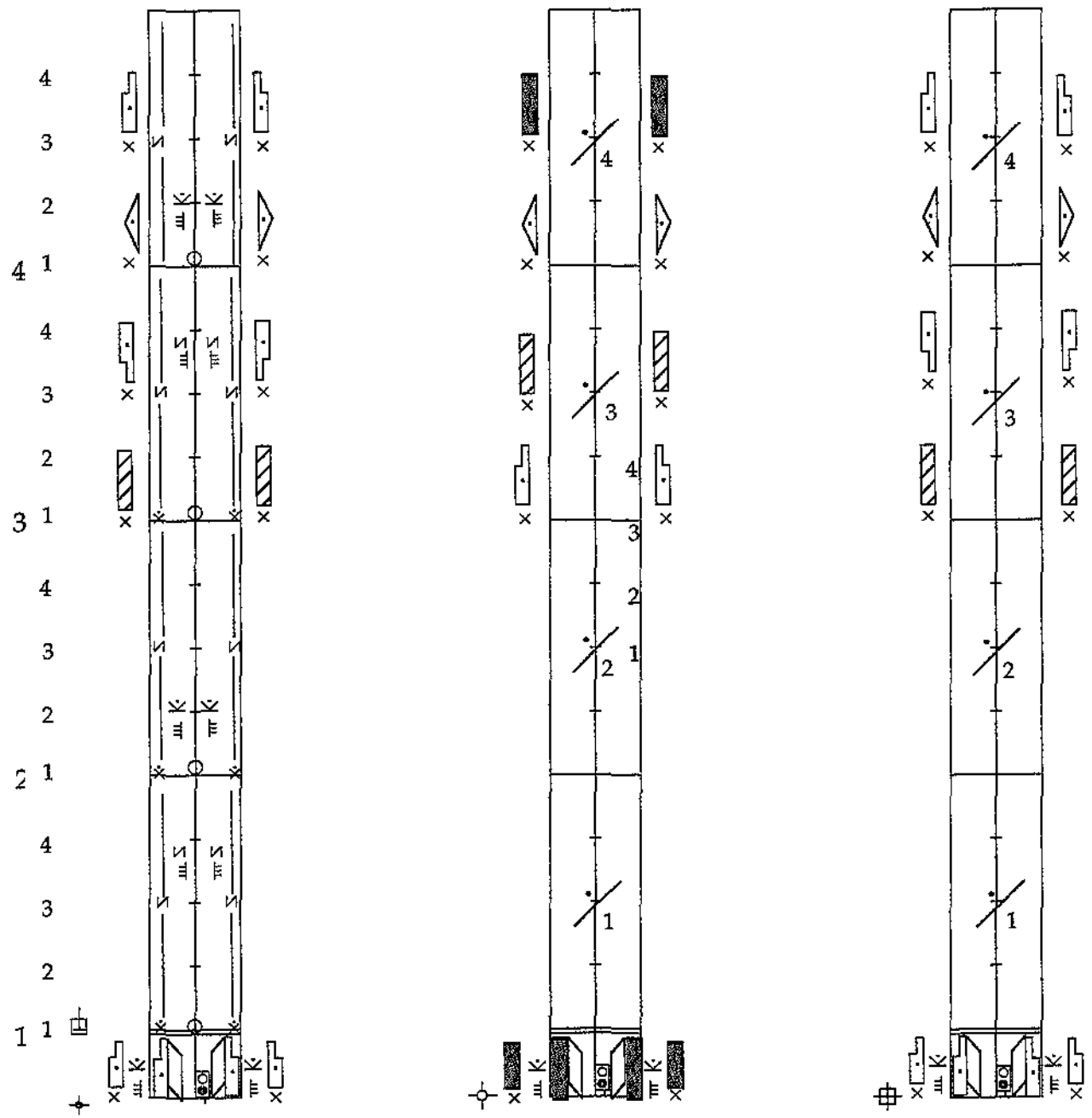

Appendix 2B

